

阅读申明

- 1.本站收集的数据手册和产品资料都来自互联网，版权归原作者所有。如读者和版权方有任何异议请及时告之，我们将妥善解决。
- 2.本站提供的中文数据手册是英文数据手册的中文翻译，其目的是协助用户阅读，该译文无法自动跟随原稿更新，同时也可能存在翻译上的不当。建议读者以英文原稿为参考以便获得更精准的信息。
- 3.本站提供的产品资料，来自厂商的技术支持或者使用者的心得体会等，其内容可能存在描述上的差异，建议读者做出适当判断。
- 4.如需与我们联系，请发邮件到marketing@iczoom.com，主题请标有“数据手册”字样。

Read Statement

1. The datasheets and other product information on the site are all from network reference or other public materials, and the copyright belongs to the original author and original published source. If readers and copyright owners have any objections, please contact us and we will deal with it in a timely manner.
2. The Chinese datasheets provided on the website is a Chinese translation of the English datasheets. Its purpose is for reader's learning exchange only and do not involve commercial purposes. The translation cannot be automatically updated with the original manuscript, and there may also be improper translations. Readers are advised to use the English manuscript as a reference for more accurate information.
3. All product information provided on the website refer to solutions from manufacturers' technical support or users the contents may have differences in description, and readers are advised to take the original article as the standard.
4. If you have any questions, please contact us at marketing@iczoom.com and mark the subject with "Datasheets" .

DIGITAL OUTPUT PRESSURE SENSORS

Enhanced Digital Output Sensors

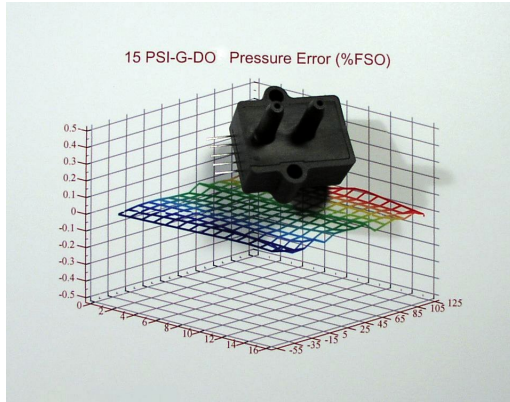

Features

- 5" H₂O to 100psi Pressure Ranges
- All Combined Errors Over Temperature Less Than 0.1%, Typical
- Wide -20 to 85°C Compensated Temperature Range
- Electrically Compatible to All Sensors GA142 Series
- Enhanced Dual Serial Interface Mode

Applications

- Medical Instrumentation
- Environmental Controls
- HVAC
- Meteorology

General Description

The Digital Output pressure sensors are based upon a proprietary surface mapping technology to produce a fully digital output that virtually eliminates all repeatable errors over temperature and pressure. This series provides a 12 bit digital serial output (14 bit in High Resolution Mode) with superior offset, span and linearity characteristics. The output is SPI and MICROWIRE/PLUS[®] compatible as well as fully compatible with the All Sensors GA142 Series sensors.

In addition to synchronous communications, the Digital Output pressure sensors incorporates a bi-directional, TTL level, asynchronous serial interfaces mode (hardware selectable 9,600 or 19,200 baud). This mode includes a command set that allows the host to interrogate the sensor for model information, pressure range, serial number, pressure units and conversion factor. The command set also allows the host to select a high resolution output mode, make minor adjustments to offset and has an addressable feature that allows multiple sensors to be tied to the same interface buss.

This series is intended for use with non-corrosive, non-ionic working fluids such as air, dry gases and the like. All signals are 5V TTL/CMOS compatible.

Physical Dimensions

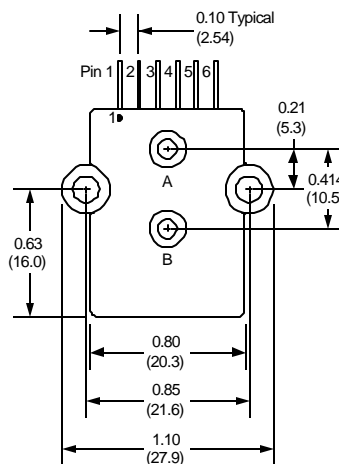
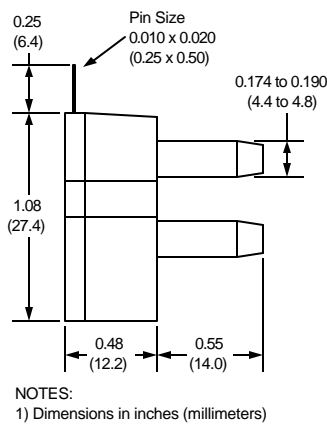

Pin Descriptions

Pin	Label	Description
1	Vcc	+5V power supply input
2	Data/SI	Data output for synchronous mode. Serial in for asynchronous mode.
3	Clock/SO	Clock output for synchronous mode. Serial out for asynchronous mode.
4	Ready/Mode	Ready output for synchronous mode. Selects asynchronous mode when held low during reset.
5	Convert/BR	Convert input for synchronous mode. Selects one of two baud rates for asynchronous mode (low=9,600, high=19,200).
6	Ground	Ground for power and signals



Absolute Maximum Ratings

Supply Voltage (Vcc)	7Vdc
Voltage on Any Pin with Respect to Gnd	-0.6 to Vcc+0.6V
Common-mode pressure	50 psig
Lead Temperature (soldering 2-4 sec.)	250°C

Environmental Specifications

Operating Voltage	+4.75Vdc to +5.25Vdc
Compensated Temperature	-20° C to +85° C
Operating Temperature	-25 to +90° C
Storage Temperature	-40 to 125° C
Humidity Limits	0 to 95% RH (non condensing)

Standard Pressure Ranges

Part Number	Operating Pressure	Units	FSO ⁽²⁾	Digital Span ⁽⁴⁾	Proof Pressure	Burst Pressure
5 INCH-D-DO	-5 to 5	inH2O	5	1	200 inH2O	300 inH2O
10 INCH-D-DO	-10 to 10	inH2O	10	1	200 inH2O	300 inH2O
20 INCH-D-DO	-20 to 20	inH2O	20	1	200 inH2O	500 inH2O
30 INCH-D-DO	-30 to 30	inH2O	30	1	200 inH2O	800 inH2O
1 PSI-D-DO	-1 to 1	PSI	1	1	5 PSI	15 PSI
5 PSI-D-DO	-5 to 5	PSI	5	1	10 PSI	30 PSI
15 PSI-D-DO	-15 to 15	PSI	15	1	60 PSI	120 PSI
15 PSI-A-DO	0 to 15	PSIA	15	2	60 PSI	120 PSI
BARO-DO	600 to 1100	mBar	1100	3	60 PSI	120 PSI
30 PSI-G-DO	0 to 30	PSI	30	2	90 PSI	150 PSI
30 PSI-A-DO	0 to 30	PSIA	30	2	90 PSI	150 PSI
100 PSI-G-DO	0 to 100	PSI	100	2	200 PSI	250 PSI
100 PSI-A-DO	0 to 100	PSIA	100	2	200 PSI	250 PSI

General Performance Characteristics (All Models)

Parameter ⁽¹⁾	Minimum	Nominal	Maximum	Units
Resolution	12	--	--	Bit
Conversion Speed	--	8	16	mS
Supply Current	--	8	12	mA

Performance Characteristics for 5 INCH-D-DO

Parameter ⁽¹⁾	Minimum	Nominal	Maximum	Units
Overall Accuracy ⁽⁵⁾	--	0.25	0.5	%FSO
Long Term Drift (one year)	--	--	0.5	%FSO
Offset Position Sensitivity (1g)	--	--	0.05	%FSO
Offset Warm-up Shift ⁽³⁾	--	--	0.25	%FSO

Performance Characteristics for 10 INCH-D-DO, 20 INCH-D-DO and 30 INCH-D-DO

Parameter ⁽¹⁾	Minimum	Nominal	Maximum	Units
Overall Accuracy ⁽⁵⁾	--	0.25	0.5	%FSO
Long Term Drift (one year)	--	--	0.5	%FSO
Offset Position Sensitivity (1g)	--	--	0.03	%FSO
Offset Warm-up Shift ⁽³⁾	--	--	0.25	%FSO

Performance Characteristics for 10 INCH-D-DO, 20 INCH-D-DO and 30 INCH-D-DO

Parameter ⁽¹⁾	Minimum	Nominal	Maximum	Units
Overall Accuracy ⁽⁵⁾	--	0.25	0.5	%FSO
Long Term Drift (one year)	--	--	0.5	%FSO
Offset Position Sensitivity (1g)	--	--	0.03	%FSO
Offset Warm-up Shift ⁽³⁾	--	--	0.25	%FSO

Performance Characteristics for BARO-DO

Parameter ⁽¹⁾	Minimum	Nominal	Maximum	Units
Overall Accuracy ⁽⁵⁾	--	1.0	2.5	mBar
Long Term Drift (one year)	--	--	2.0	mBar

Performance Characteristics for 1 PSI-D-DO through 100 PSI-A-DO (except BARO-DO)

Parameter ⁽¹⁾	Minimum	Nominal	Maximum	Units
Overall Accuracy ⁽⁵⁾	--	0.10	0.25	%FSO
Long Term Drift (one year)	--	--	0.25	%FSO

Specification Notes

- NOTE 1: UNLESS OTHERWISE SPECIFIED, ALL PARAMETERS ARE MEASURED AT 5.0 VOLT SUPPLY, POSITIVE PRESSURE APPLIED TO PORT B.
- NOTE 2: THE DIGITAL OUTPUT IS A 16 BIT SIGNED BINARY OUTPUT IN A TWO'S COMPLIMENT FORMAT. THE APPLIED PRESSURE IS COMPUTED USING THE PRESSURE CONVERSION TABLE (BELOW). THE MODE COLUMN IDENTIFIES THE RESOLUTION OPERATING MODE OF THE DEVICE (A = STANDARD RESOLUTION, B = HIGH RESOLUTION). FSO AND UNITS ARE SHOWN FOR EACH MODEL.
- NOTE 3: SHIFT IS WITHIN THE FIRST HOUR OF EXCITATION APPLIED TO THE DEVICE.
- NOTE 4: DIGITAL SPAN IS DEPENDENT ON THE RESOLUTION OPERATING MODE. REFER TO THE DIGITAL SPAN TABLE (BELOW) TO IDENTIFY THE DIGITAL SPAN OF THE SPECIFIC MODEL. IN THE EVENT OF AN OVER-PRESSURE OR UNDER-PRESSURE CONDITION, THE DIGITAL OUTPUT WILL ONE COUNT HIGHER OR ONE COUNT LOWER (RESPECTIVELY) TO THE LISTED DIGITAL SPAN TO INDICATE THE CONDITION.
- NOTE 5: OVERALL ACCURACY INCLUDES THE COMBINED EFFECTS OF OFFSET AND SPAN SHIFTS OVER TEMPERATURE, LINEARITY, HYSTERESIS, AND OFFSET AND SPAN CALIBRATION.

Digital Span Table

Span	Mode S (Standard)	Mode H (High Res)
1	-10,399 to 10,399	-32,767 to 32,766
2	-399 to 10,399	-999 to 32,766
3	5,054 to 10,399	17,501 to 32,766

Pressure Conversion Table

Mode	Pressure Output Equation
S	$P_{Out} = Digital_Out \cdot \left(\frac{FSO \cdot Units}{10,000} \right)$
H	$P_{Out} = Digital_Out \cdot \left(\frac{FSO \cdot Units}{32,767} \right)$

Typical Configurations

Synchronous Communications

Typical synchronous communications configuration (compatible with All Sensors GA142 Series Digital Output Sensors).

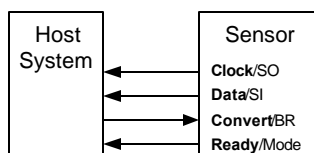

Asynchronous Communications

Typical asynchronous communications configuration. The Mode pin is interrogated at power up and if tied low, will cause the sensor to enter asynchronous communications mode. This mode supports multiple sensors by addressable commands. The Convert/BR pin then serves to select one of two available baud rates.

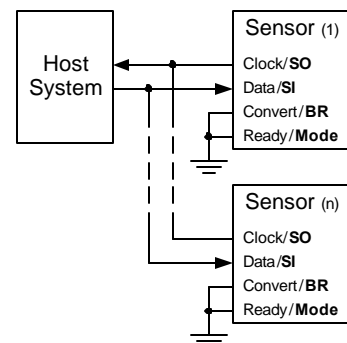

Asynchronous Command Summary ^(1,2)

Command	Description	Response
RD	Read Mode Setting	RD=<Mode>
RM	Read Model Information	RM=<Model String>
RO	Read User Offset Setting	RO=<hhhh>
RP	Read Pressure	RP=<hhhh>
RR	Read Device Pressure Range	RR=<Range String>
RS	Read Serial Number	RS=<Serial Number String>
WD<Mode>	Write Mode Setting (“S” = Standard, “H” = High Resolution)	WD=<Mode>
WO<Offset>	Write User Offset Setting	WO=<hhhh>
U<S/N><Cmd>	Select Unique Part for following command (for multidrop configurations).	U<S/N><Cmd>

Asynchronous Command Notes

NOTE 1: ALL COMMANDS AND RESPONSES ARE IN ASCII CHARACTER FORMAT AND ARE TERMINATED BY A CARRIAGE RETURN (CARRIAGE RETURNS ARE NOT SHOWN IN COMMAND AND RESPONSE TABLE). EXAMPLE: THE READ PRESSURE COMMAND (REPRESENTED BY: RP<CR>) IS GIVEN BY THE FOLLOWING THREE BYTE SEQUENCE: 0x52 0x50 0x0D

NOTE 2: <HHHH> IS A FOUR BYTE ASCII STRING REPRESENTING A 16-BIT SIGNED VALUE. EXAMPLE: P=2B7D REPRESENTS THE RESPONSE OF AN RP COMMAND WITH THE PRESSURE OUTPUT OF 0x2B7D (11,133 DECIMAL) VALUE.

Synchronous Timing Diagram (Note: Asynchronous mode timing is per RS-232)

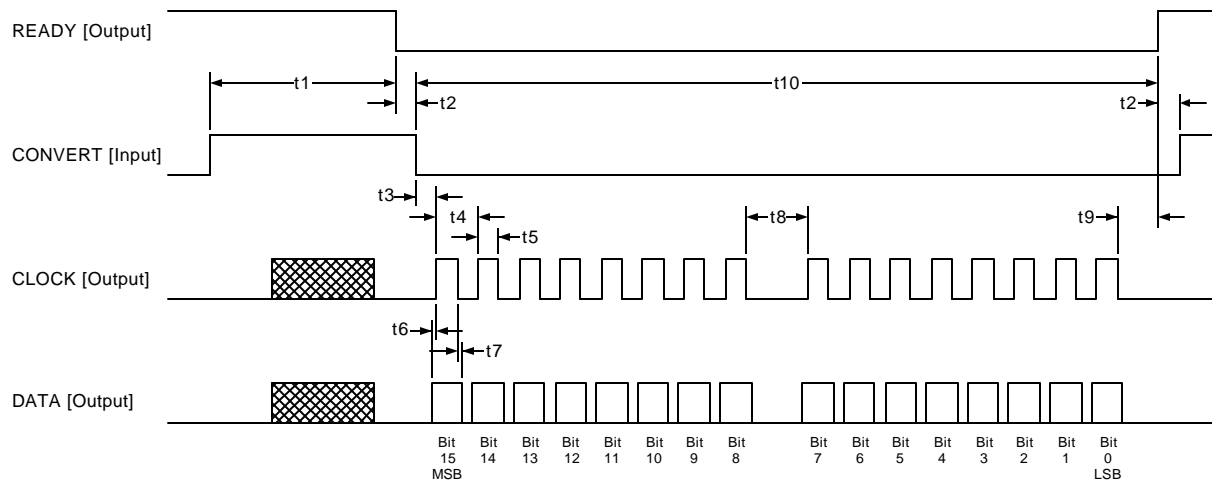

Ref	Parameter	Min	Typ	Max	Units
t1	Conversion Time	--	8	16	msec
t2	Ready to Convert	0	--	--	usec
t3	Convert to Clock	24	32	39	usec
t4	Clock Period	--	16	--	usec
t5	Clock High Time	--	8	--	usec

Ref	Parameter	Min	Typ	Max	Units
t6	Data Setup Time	--	3	--	usec
t7	Data Hold Time	--	3	--	usec
t8	Interbyte Delay	--	57	--	usec
t9	Clock to Ready	--	14	--	usec
t10	Data Transmission	--	335	--	usec

All Sensors reserves the right to make changes to any products herein. All Sensors does not assume any liability arising out of the application or use of any product or circuit described herein, neither does it convey any license under its patent rights nor the rights of others.

® MICROWIRE/PLUS IS A REGISTERED TRADEMARK OF NATIONAL SEMICONDUCTOR.